

Engineering Data Sheet

Document No:- 002B00100D799 rev 6

Installation, Operation & Maintenance Instructions for
Fig 100 series Copper Alloy Ball Valves

Page 1 of 5

Date 16th January 2009

Operating pressures and temperatures

This includes the Fig 100(¼" to 4"), Fig 100LS (¼" to 2"), Fig 100T(¼" to 1"), Fig 100EXT(½" to 4"), Fig 100HU (½" to 1").

Valve Size	PN	Non-shock pressure at temperature range	Non-shock pressure at max. temperature
15mm-54mm ¼" - 2" 2½" - 4"	16 Compression 25 Threaded 20 Threaded	16 bar from -10°C to 30°C 25 bar from -10°C to 100°C 20 bar from -10°C to 20°C	5 bar at 120 °C 21.8 bar at 120 °C 6 bar at 120 °C

Not suitable for fatigue loading, creep conditions, fire testing, fire hazard environment, corrosive or erosive service, transporting fluids with abrasive solids.

PRESSURE/TEMPERATURE RATING

These valves are suitable for PN16 compression and PN25 threaded pressure ratings. They must be installed in a piping system where the normal pressure and temperature do not exceed the above ratings.

If system testing will subject the valve to pressures in excess of the working pressure rating, this should be within the test pressure for the body with the valve in the open position.

The maximum allowable pressure in valves as specified in the standards is for non-shock conditions. Water hammer and impact for example, should be avoided.

If the limits of use specified in these instructions are exceeded or if the valve is used on applications for which it was not designed, a potential hazard could result.

LAYOUT AND SITING

It should be considered at the design stage where valves will be located to give access for operation, adjustment, maintenance and repair.

Valves must be provided with adequate support. Adjoining pipework must be supported to avoid the imposition of pipeline strains on the valve body, which would impair its performance.

The Fig 100 Series are bi-directional valves and can be installed in any flow direction.

The Fig 100HU may be installed in any orientation but attention should be paid to surrounding structures, ensuring that the hose union connection may be easily accomplished and that the valve lever movement is not impaired

Care is needed during installation to provide sufficient room to enable the valve to be operated. (For lockshield and Hose Union valves this needs to be a minimum of 175mm)

In the interests of safety, valves installed on end-of-line service in the closed position with infrequent opening should be fitted with a locking device on the operating mechanism. Alternatively, it should be fitted with a blanking plug or cap on the downstream end connection of the valve.

Engineering Data Sheet

Document No:- 002B00100D799 rev 6

Installation, Operation & Maintenance Instructions for
Fig 100 series Copper Alloy Ball Valves

Page 2 of 5

Date 16th January 2009

INSTALLATION

Prior to installation, a check of the identification plate and body marking must be made to ensure that the correct valve is being installed.

Valves are precision manufactured items and as such, should not be subjected to misuse such as careless handling, allowing dirt to enter the valve through the end ports, lack of cleaning both valve and system before operation and excessive force during lever operation.

All special packaging material must be removed.

Valves must be provided with adequate support. Adjoining pipework must be supported to avoid the imposition of pipeline strains on the valve body, which would impair its performance.

Immediately prior to valve installation, the pipework to which the valve is to be fastened should be checked for cleanliness and freedom from debris.

Compression End Valves

Copper Pipe

These valves are fitted with compression ends to BS EN 1254-2 (formerly BS 864 Part 2), which are suitable for installation into copper pipework to BS EN 1057: R250 (half hard) and are provided with olives and compression nuts.

When installing a valve with compression ends to copper tube;

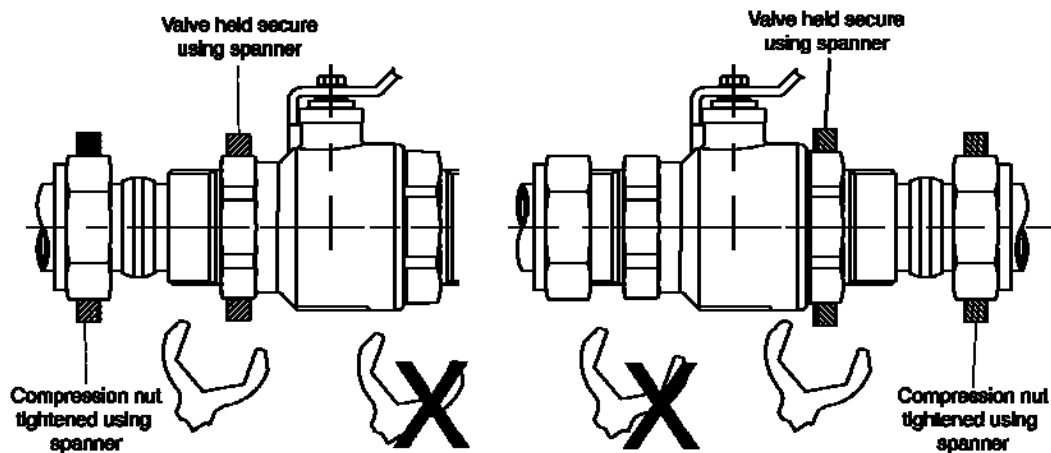

- Always use a correctly sized spanner or wrench on the flats provided.
- Do not grip around the valve body joint.
- Never drive torque through the main body joint during assembly.

Compression nuts must be hand tightened and then further tightened as per the following recommendation:

	15mm	22mm	28mm	35mm	42mm	54mm
Further Tightening	Between $\frac{3}{4}$ and $1\frac{1}{4}$ turns					

Engineering Data Sheet

Document No:- 002B00100D799 rev 6

Installation, Operation & Maintenance Instructions for
Fig 100 series Copper Alloy Ball Valves

Page 3 of 5

Date 16th January 2009

Threaded End Valves

When installing a valve with threaded ends to steel pipe;

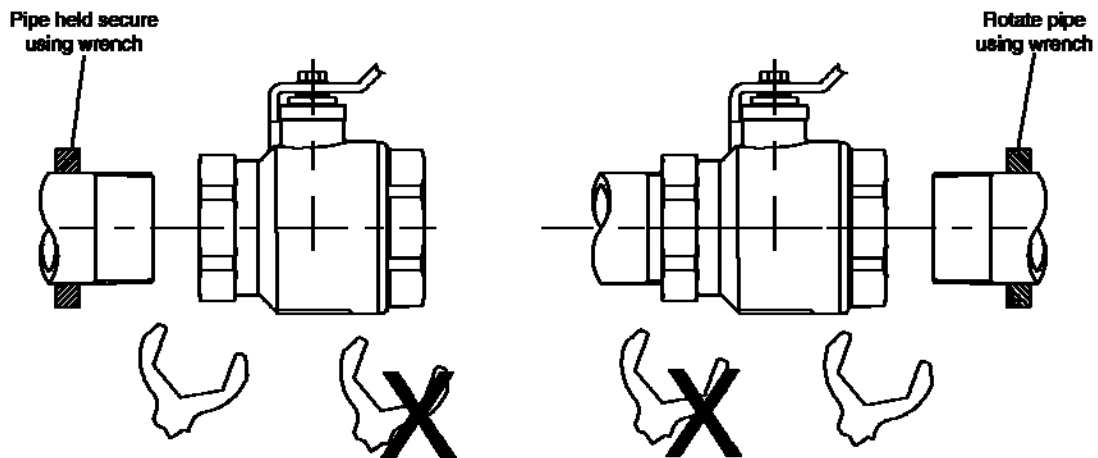

- Always use the flats on the hexagon at the end being fitted to the pipe.
- Always use a correctly sized spanner or wrench on the flats provided.
- Do not grip around the valve body joint.
- Never drive torque through the main body joint during assembly.
- Screw the pipe into valve and hand tighten, then tighten by the number of turns shown below (up to one additional turn is permitted for alignment).

Valve Size	Turns	Valve Size	Turns	Valve Size	Turns
¼ - 1.1/2"	1.5	2"	2	2.1/2" - 4"	2.5

Mapress Pipe

When used with Mapress carbon or stainless steel pipes, Mapress pipe to male BSP threaded fittings must be used.

Hose Union valves

Remove hose union nut and tailpipe taking care not to lose the tail pipe seal.

The valve ends are threaded parallel therefore the valve must be fully tightened up to the body shoulder. Sealing compounds may be used and a sealing washer on the body shoulder would provide additional security.

The wrench must only be located on the valve end into which the pipe is being threaded to avoid distortion of the valve.

After installation, the valve may be opened and closed fully to confirm satisfactory operation.

OPERATION

Ball valves have a quarter turn operation (clockwise to close) providing quick and positive isolation.

To close the valve, the handle or key is rotated clockwise to a positive stop.

Engineering Data Sheet

Document No:- 002B00100D799 rev 6

Installation, Operation & Maintenance Instructions for
Fig 100 series Copper Alloy Ball Valves

Page 4 of 5

Date 16th January 2009

To open the valve, the handle or key is rotated anti-clockwise to a positive stop.

Note: The operator should use suitable hand protection at extreme temperature conditions.

Note: Rapid closure of a quarter turn valve on liquid services may cause system water hammer.

Ball valves have PTFE body seats and should only be used in the full open or closed positions.

For operation purposes the ball valve is provided with either a lever handle, T-handle or Lockshield.

Where a Lockshield is fitted:

- Remove plastic cover to access drive mechanism.
- Valve may be open or closed using standard hex spanners / sockets.
- Replace Lockshield cover after operation.

If valve is to be locked either open or closed:

- Remove retaining nut from drive mechanism
- Lift drive mechanism and turn through 90° ensuring slot in mechanism locates on body stop tang.
- Refit retaining nut
- Replace Lockshield cover

MAINTENANCE

The Hattersley Ball valve is maintenance free and will have a long service life.

The valve should be at zero pressure and ambient temperature prior to any inspection.

Maintenance Engineers & Operators are reminded to use correct fitting tools and equipment.
A full risk assessment and methodology statement must be compiled prior to any maintenance.

The risk assessment must take into account the possibility of the limits of use being exceeded whereby a potential hazard could result.

A maintenance programme should therefore include checks on the development of unforeseen conditions, which could lead to failure.

For the supply of genuine Hattersley spares or technical assistance please use the contact details:

Engineering Data Sheet

Document No:- 002B00100D799 rev 6

Installation, Operation & Maintenance Instructions for
Fig 100 series Copper Alloy Ball Valves

Page 5 of 5

Date 16th January 2009

CE MARKING AND THE PRESSURE EQUIPMENT DIRECTIVE 97/23/EC

This has been implemented in United Kingdom law by the Pressure Equipment Regulations 1999 (SI 1999/2001).

The regulations apply to all valves with a maximum allowable pressure greater than 0.5 bar. Valves with a maximum allowable pressure not exceeding 0.5 bar are outside the scope of the Directive. Valves are categorised in accordance with the maximum working pressure, size and ascending level of hazard, which is dependent on the fluid being transported. Fluids are classified as Group 1, dangerous fluids or Group 2, all other fluids including steam. Categories are SEP (sound engineering practice) and for ascending levels of hazard, I, II, III or IV. All valves designated as SEP do not bear the CE mark nor require a Declaration of Conformity. Categories I, II, III or IV carry the CE mark and require a Declaration of Conformity (Note- all valves up to and including 25mm (1") having a maximum allowable pressure greater than 0.5 bar are designated SEP regardless of fluid group.)

PRODUCT LIFE CYCLE

The life of the valve is dependent on its application, frequency of use and freedom from misuse. Compatibility with the system into which it is installed must be considered. The properties of the fluid being transported such as pressure, temperature and the nature of the fluid must be taken into account to minimise or avoid premature failure or non-operability. A well-designed system will take into consideration all the factors considered in the valve design, but additionally electrolytic interaction between dissimilar metals in the valve and the system must be examined. Before commissioning a system, it should be flushed to eliminate debris and chemically cleaned as appropriate to eliminate contamination, all of which will prolong the life of the valve.

LIMITS OF USE

The valves to which these installation, operation and maintenance instructions apply have been categorised in accordance with the Pressure Equipment Directive.

The fluid to be transported is limited to Group 2 gases i.e. non-hazardous and on no account must these valves be used on any Group 1 gases or Group 1 liquids.

These valves may be used on Group 2 liquids

Valves should not be used on steam service.

Fluid	Group 2 Gases			
Fig No.	Ends	PN	Size	Category
100C	Compression	16	15 - 54	SEP
100	Threaded	25	½" - 1½"	SEP
		25	2"	I *
		20	2½" - 4"	I *

* Category I requires CE mark

Contact Hattersley for Technical Support on:

Telephone : 01473 277400

Facsimile : 01473 277411

Email : uksales@hattersley.com
: export@hattersley.com