

100HU



Dezincification Resistant Male Hose Union with Threaded End

FEATURES AND BENEFITS

- Worldwide availability
- High Quality Range
- Long and trouble-free service life
- Full bore
- Ends threaded to BS EN 10226-2



MATERIALS

Name	Material	Quantity
Shield Cover	Polypropelyne	1
Hex-Nut	Steel Dacromet Plated	1
Lockshield	CW617N	1
Packing Nut	CW617N	1
Packing Gland	PTFE with WRAS approval	1
Body	CW602N	1
Ball	CW602N Chrome Plated	1
Seats	PTFE with WRAS approval	2
O-Ring	EPDM with WRAS approval	1
Bonnet	CW602N	1
Washer	PTFE with WRAS approval	1
Tailpiece	CW602N	1
Union Ring	CW602N	1
Stem	CW602N	1

DIMENSIONS AND WEIGHTS

Size (mm)	L (mm)	L2 (mm)	H (mm)
R 1/2"	84	58	41.8
R 3/4"	98	66	45.3
R 1"	109	77	57.7

All dimensions are nominal.

DIMENSIONAL DRAWING

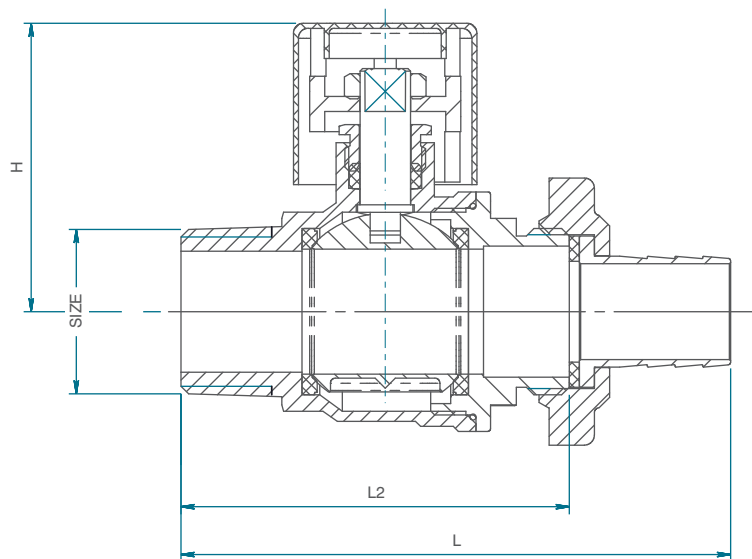

Pressure Rating: PN25 • UK End Connection: BS EN 10226-2: 2005 formerly BS21 Taper
 US End Connection: ANSI B1.20.1: 1983 Operator: Lockshield

Specification: Quarter Turn | PTFE seats and stem seal | WRAS listed.



PO BOX 719, IPSWICH, IP1 9UD
 HOME SALES: +44 (0)1744 458670
 EXPORT SALES: +44 (0)1744 458671
 TECHNICAL HELPLINE: 0845 604 1790
 FAX: +44 (0)1744 26912
 EMAIL: uksales@hattersley.com
 EMAIL: export@hattersley.com
www.hattersley.com
 The Company reserve the right to amend any product without notice.

H_L_100MHU_05_2010