

Engineering Data Sheet

Document No:- 050M00950D799 rev 6

Page 1 of 7

Installation, Operation & Maintenance Instructions for 950 and 970 Series Butterfly Valves including Double Regulation

Date 11th September 2006

CE MARKING AND THE PRESSURE EQUIPMENT DIRECTIVE 97/23/EC

This has been implemented in United Kingdom law by the Pressure Equipment Regulations 1999 (SI 1999/2001).

The regulations apply to all valves with a maximum allowable pressure greater than 0.5 bar. Valves with a maximum allowable pressure not exceeding 0.5 bar are outside the scope of the Directive. Valves are categorised in accordance with the maximum working pressure, size and ascending level of hazard, which is dependent on the fluid being transported. Fluids are classified as Group 1, dangerous fluids or Group 2, all other fluids including steam. Categories are SEP (sound engineering practice) and for ascending levels of hazard, I, II, III or IV. All valves designated as SEP do not bear the CE mark nor require a Declaration of Conformity. Categories I, II, III or IV carry the CE mark and require a Declaration of Conformity (Note- all valves up to and including 25mm (1") having a maximum allowable pressure greater than 0.5 bar are designated SEP regardless of fluid group.)

PRODUCT LIFE CYCLE

The life of the valve is dependent on its application, frequency of use and freedom from misuse. Compatibility with the system into which it is installed must be considered. The properties of the fluid being transported such as pressure, temperature and the nature of the fluid must be taken into account to minimise or avoid premature failure or non-operability. A well-designed system will take into consideration all the factors considered in the valve design, but additionally electrolytic interaction between dissimilar metals in the valve and the system must be examined. Before commissioning a system, it should be flushed to eliminate debris and chemically cleaned as appropriate to eliminate contamination, all of which will prolong the life of the valve.

LIMITS OF USE

The valves to which these installation, operation and maintenance instructions apply have been categorised in accordance with the Pressure Equipment Directive.

The fluid to be transported is limited to Group 2 liquids i.e. non-hazardous and on no account must these valves be used on any Group 2 gases, Group 1 liquids or Group 1 gases.

Fluid	Group 2 Liquid only		
Fig No.	Rating	DN	Category
950	PN16	50-300 350-700	SEP I*
970 and 4970	PN16	50-300 350-700	SEP I*
950W#	PN16	50-300	SEP
970W#	PN16	50-300	SEP
950ANSI	ANSI 125	2"- 12" 14"- 28"	SEP I*
4970ANSI	ANSI 125	2"- 12" 14"- 28"	SEP I*

* Category I requires the CE mark

WRAS Approved Products

Engineering Data Sheet

Document No:- 050M00950D799 rev 6

Page 2 of 7

Installation, Operation & Maintenance Instructions for 950 and 970 Series Butterfly Valves including Double Regulation

Date 11th September 2006

Operating pressures and temperatures

Pressure Rating	Fig No	Seat Trim	Non-shock pressure at temperature range	Non-shock pressure at max. temperature
16	950, 970 & 4970	EPDM	16 bar from -10°C to 130°C	16 bar at 130 °C
16	950W & 970W	EPDM	16 bar from -10°C to 110°C	16 bar at 110°C
ANSI 125 up to 12"	950 & 4970	EPDM	13.8 bar from -10°C to 65°C	12.1 bar at 120 °C
ANSI 125 14" & above	950 & 4970	EPDM	10.3 bar from -10°C to 65°C	8.6 bar at 120 °C

Not suitable for fatigue loading, creep conditions, fire testing, fire hazard environment, corrosive or erosive service, transporting fluids with abrasive solids.

PRESSURE/TEMPERATURE RATING

These valves must be installed in a piping system whose normal pressure and temperature do not exceed the above ratings.

If system testing will subject the valve to pressures in excess of the working pressure rating, this should be within the test pressure for the body with the valve open, i.e. 1.5 x maximum seat pressure rating.

The maximum allowable pressure in valves as specified in the standards is for non-shock conditions. Water hammer and impact for example, should be avoided.

If the limits of use specified in these instructions are exceeded or if the valve is used on applications for which it was not designed, a potential hazard could result.

END OF LINE SERVICE

Valves categorised as **Category SEP** or **Category I** are suitable for end-of-line application at the pressures indicated, regardless of the pressure rating.

Sizes DN50 to DN300: 10 bar Sizes DN350 to DN700: 6 bar

In the interest of safety, valves installed in the closed position where operation will be required, should be fitted with a locking device to prevent unauthorised operation.

Valves left unattended for prolonged periods should be fitted with a blanking flange on the downstream end of the valve. This is also recommended where the valve will be operated infrequently.

LAYOUT AND SITING

These butterfly valves, when fitted with a double regulating device, Fig 953, 973 and 4973 may be used in conjunction with a Fig 5000 Metrex metering station or a Fig M2000 metering station. When used with the Fig M2000 a spool piece must be fitted between the metering station and the valve with a minimum length of 1.5 x the nominal pipe diameter.

Flow must pass through the metering station first and secondly through the valve.

Engineering Data Sheet

Document No:- 050M00950D799 rev 6

Page 3 of 7

Date 11th September 2006

Installation, Operation & Maintenance Instructions for 950 and 970 Series Butterfly Valves including Double Regulation

These valves can be fitted in either horizontal or vertical pipework. When installed in a horizontal pipeline, the valve stem should be preferably horizontal. This enables the butterfly valve to be self-cleaning and also enables the weight of the disk to be equally borne by the bearings.

It should be considered at the design stage where valves will be located to give access for operation, adjustment, maintenance and repair.

Valves must be provided with adequate support. Adjoining pipework must be supported to avoid the imposition of pipeline strains on the valve body, which would impair its performance. Heavy valves may need independent support or anchorage.

INSTALLATION

The Fig 950 Series are semi-lugged valves with combined location between the bolt circle diameter and flange drilling.

The Fig 970 Series are fully-lugged valves and are located between flanges utilizing the flange bolt holes.

The flange bolts or studs should be tightened diagonally until the body touches the flange face with metal to metal contact.

Prior to installation, a check of the identification plate and body marking must be made to ensure that the correct valve is being installed.

Valves are precision manufactured items and as such, should not be subjected to misuse such as careless handling, allowing dirt to enter the valve through the end ports, lack of cleaning both valve and system before operation and excessive force during bolting and handwheel/lever operation.

All special packaging material must be removed.

Valves must be provided with adequate support. Adjoining pipework must be supported to avoid the imposition of pipeline strains on the valve body, which would impair its performance.

When large valves are provided with lifting lugs or eye nuts, these should be used to lift the valve.

Immediately prior to valve installation, the pipework to which the valve is to be fastened should be checked for cleanliness and freedom from debris.

Valve packaging should only be permanently removed immediately before installation. The valve interior should be inspected through the end ports to determine whether it is clean and free from foreign matter. The mating flange (both valve and pipework flanges) should be checked for correct gasket contact face, surface finish and condition. If a condition is found which might cause leakage, no attempt to assemble should be made until the condition has been corrected.

These butterfly valves have integral rubber sealing faces and gaskets must **not** be used.

In order to maintain an effective sealing face with the pipe flange, integral, weld-neck, slip-on or loose plate flanges should be used.

When using slip-on flanges the pipe must be flush with the raised face as shown. If the pipe stops short this will reduce the sealing width and can cause leakage from the joint.

Engineering Data Sheet

Document No:- 050M00950D799 rev 6

Page 4 of 7

Date 11th September 2006

Installation, Operation & Maintenance Instructions for 950 and 970 Series Butterfly Valves including Double Regulation

Loose plate flanges with weld neck or slip on collars are used with copper pipe, care should be taken to ensure that the raised face covers the outer metal compression stop on the butterfly valve otherwise the rubber line can be over compressed and the valve becomes inoperable.

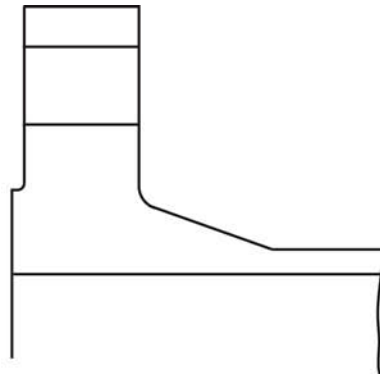

Integral Flange

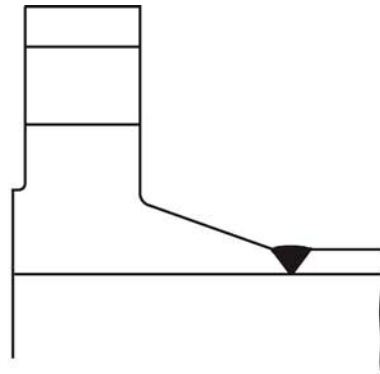

Weld Neck Flange

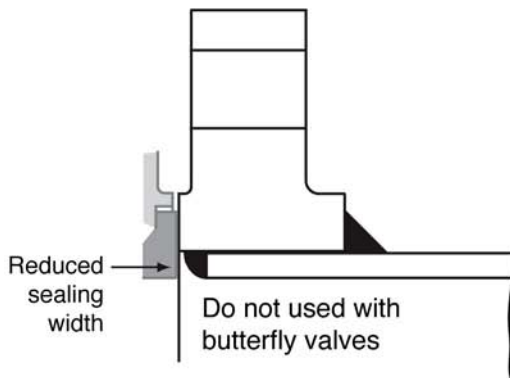

Slip On Welding Flange

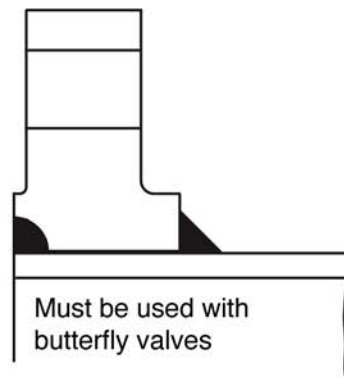

Slip On Welding Flange

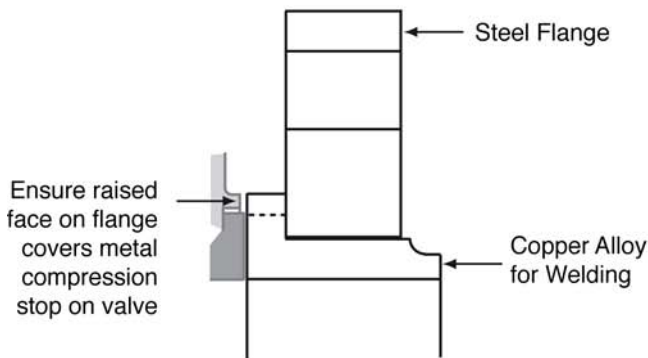

Loose Plate Flange with Weld Neck Collar

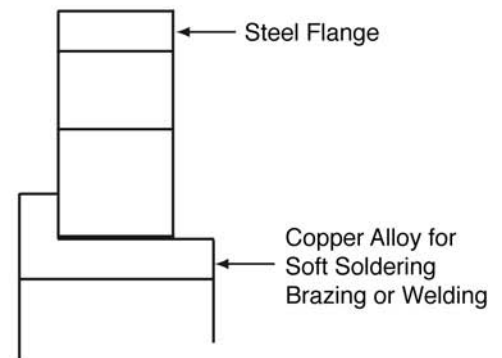

Loose Plate Flange with Slip On Collar

Engineering Data Sheet

Document No:- 050M00950D799 rev 6

Page 5 of 7

Date 11th September 2006

Installation, Operation & Maintenance Instructions for 950 and 970 Series Butterfly Valves including Double Regulation

Care should be taken to provide correct alignment of the flanges being assembled. Suitable lubricant on bolt threads should be used. In assembly, bolts are tightened sequentially to make the initial contact of flanges and gaskets flat and parallel followed by gradual and uniform tightening in an opposite bolting sequence to avoid bending one flange relative to the other, particularly on flanges with raised faces.

Parallel alignment of flanges is especially important in the case of the assembly of a valve into an existing system.

Flanged joints depend on compressive deformation of the integral rubber sealing faces between the flange surfaces until metal to metal contact is achieved.

The bolting must be checked for correct size, length, material and that all connection flange bolt holes are utilized.

OPERATING

Gear Operated

An enclosed worm gear reduction operator (gearbox) is mounted on the valve body with the gear quadrant intimately connected with the valve shaft. The full open and full closed position travel stops are set at the factory and require no further adjustment.

Note:- if the gearbox is fitted with a padlock and locking ring, the padlock will require removal prior to operation.

Valve closure is by clockwise rotation of the handwheel until the travel stop restriction is felt. No excessive force is required to effect tight shut off and under no circumstances should a wrench or wheelkey be used.

Counter clockwise rotation of the handwheel will open the valve until the full open travel stop or to the intermediate regulated travel stop (memory stop) if fitted on the double regulating version.

A non-adjustable pointer indicates the actual valve disk position against a fixed scale.

The memory stop (double regulating versions only) device is fitted at the factory so that the valve may be operated over its full travel prior to commissioning without the need for adjustment.

Setting the gearbox memory stop (refer to Fig 1)

Using the usual commissioning procedures, establish the required regulated position of the valve.

Slacken the centre screw sufficiently for the travel stop arm to be lifted and disengaged from the drive spline.

Rotate the travel stop arm as near as possible to the eccentric stop 'C' at the corner of the gearbox cover and re-engage on the spline. Tighten the centre screw.

Slacken the eccentric stop screw and rotate the eccentric stop until it firmly touches the travel stop arm and re-tighten the screw.

It is recommended that the eccentric stop is rotated in a clockwise direction to touch the travel stop arm so that the tightening effect of the screw will maintain the stop position.

Record the regulation position.

Note:- Excessive-opening effort on the intermediate stop is not necessary. Handwheel effort should cease when obvious resistance is felt.

Engineering Data Sheet

Document No:- 050M00950D799 rev 6

Installation, Operation & Maintenance Instructions for 950 and 970 Series Butterfly Valves including Double Regulation

Page 6 of 7

Date 11th September 2006

Lever operated

Hydrodynamic Torque

Care must be taken when operating the valve by the lever as high rates of flow induce a hydrodynamic torque on the disk which may cause it to move position rapidly, either more open or slamming shut, depending on its initial position. The sudden movement on the lever can cause injury and if closing, water hammer on liquid service may result in system damage.

Valve closing is by clockwise motion of the lever. Squeeze the trigger to disengage the lever from the fully open (or regulated) notch position, the lever can be rotated to the closed position notch, release the trigger to secure. See note on Hydrodynamic force above.

No excessive force is required to effect tight shut off and under no circumstance should additional wrenches be used.

Squeeze the trigger to disengage, rotate the lever counter clockwise will open the valve from the closed notch to the fully open (or regulated) notch, release the trigger to secure. See note on Hydrodynamic force above.

Memory Device

The regulating device comprises two steel plates, a lower plate fixed to the valve and an upper rotation plate. An indicator mark on the lower plate shows the valve position against the moving scale on the top plate.

MAINTENANCE

These butterfly valves are maintenance free.

The valve should be at zero pressure and ambient temperature prior to any maintenance inspection.

Maintenance Engineers & Operators are reminded to use correct fitting tools and equipment. A full risk assessment and methodology statement must be compiled prior to any maintenance.

The risk assessment must take into account the possibility of the limits of use being exceeded whereby a potential hazard could result.

A maintenance programme should therefore include checks on the development of unforeseen conditions, which could lead to failure.

For the supply of genuine Hattersley spares or technical assistance contact:

Hattersley Newman Hender
Peel House, Peel Road, West Pimbo, Skelmersdale, Lancashire, WN8 9PT

Telephone : 01695 712800
Facsimile : 01695 712820
Email : uksales@hattersley.com
: export@hattersley.com

Engineering Data Sheet

Document No:- 050M00950D799 rev 6

Page 7 of 7

Date 11th September 2006

Installation, Operation & Maintenance Instructions for 950 and 970 Series Butterfly Valves including Double Regulation

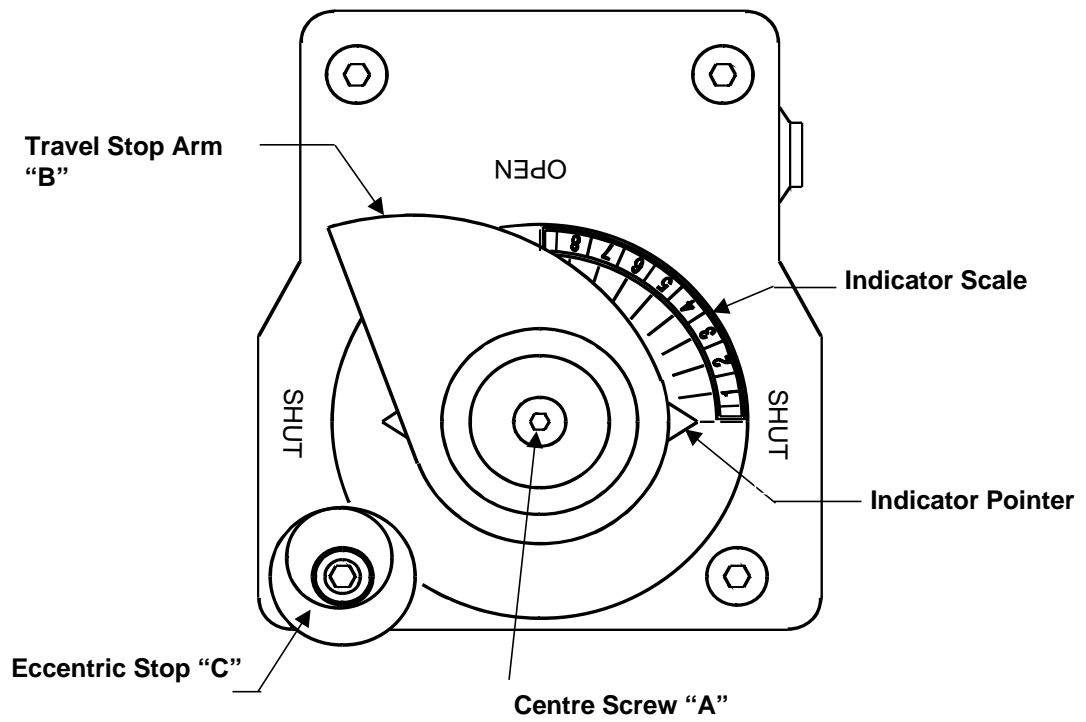

Fig 1

Fig 1